

BakerStone

THE ORIGINAL

Pizza Oven Box

Wood fired performance on your grill.

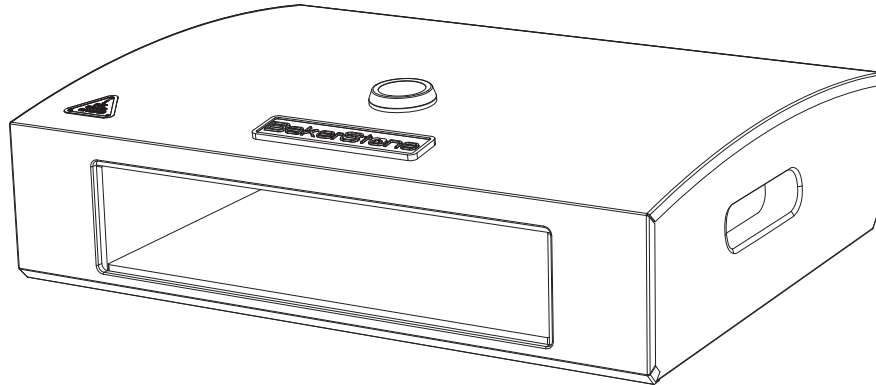

MODÈLE ORIGINAL

Boîte de Four à Pizza

Un résultat au goût de feu de bois sur votre barbecue.

Product Guide • Guide D'Utilisation • Guía de Productos

Important, Retain for Future Reference: Read Carefully
Important, le conserver pour référence Itérieure: Lisez attentivement
Importante, Guarde para referencia futura: Lea atentamente

WARNING: Read Product Guide completely before assembling the Pizza Oven Box. Failure to follow instructions and safety precautions in this guide could cause serious injury or property damage.



AVERTISSEMENT: Veuillez entièrement lire le manuel d'utilisation avant d'assembler la Boîte-four à Pizza. Le non-respect des instructions et des consignes de sécurité du guide pourraient entraîner de graves blessures et des dégâts matériels.

ADVERTENCIA: Lea la Guía del producto completo antes de armar la Pizza Oven Box. No seguir las instrucciones y precauciones de seguridad en este manual puede causar lesiones graves o daños materiales.

Safety Precautions – read before using Pizza Oven Box

To minimize the risk of serious burn injuries or property damage, follow the safety precautions below when using the Pizza Oven Box:

- ⚠ **ONLY USE YOUR PIZZA OVEN BOX ON A PROPERLY MAINTAINED, WELL VENTILATED OUTDOOR GRILL WITH THE LID FULLY OPENED AT ALL TIMES.**
- ⚠ Always wear heat resistant oven mitts or gloves designed for outdoor cooking when handling the Pizza Oven Box.
- ⚠ **DO NOT TOUCH THE PIZZA OVEN BOX WHEN IT IS ON THE GRILL, UNTIL IT HAS COMPLETELY COOLED.** The black metal housing can reach temperatures of 400°F(200°C) +/- during use.
- ⚠ Do not turn on or preheat BBQ before placing the Pizza Oven Box on the grill.
- ⚠ Do not leave the Pizza Oven Box unattended or allow unsupervised children nearby while the grill is on or coals are hot.
- ⚠ Use only appropriate bake-ware or utensils while baking and cleaning your Pizza Oven Box. Do not use plastic, silicone or glass.
- ⚠ Do not allow food other than Pizza or Bread Dough to contact the stones. Any foods that contain fat, oil or butter (meats, items coated with olive oil, cookies, biscuits, etc.) should not contact the stones directly. These items should be baked in a metal baking pan, on a metal baking sheet or in a cast-iron skillet as the stones will absorb the fat, oil and butter which can cause smoking, odors, staining, and can impart rancid flavors to items that you bake in the future.
- ⚠ **Stones are fragile and can break if dropped. THE PIZZA OVEN BOX BECOMES EXTREMELY HOT, DO NOT TOUCH THE STONES OR ANY OTHER PART OF THE PIZZA OVEN BOX WHILE IT IS IN USE.**
- ⚠ To clean stones, heat the Pizza Oven Box for 15 minutes after food is cooked and scrape off any remaining residue. Do not use any cleaning agents or other liquids to clean the stones.
- ⚠ **DO NOT REMOVE PIZZA OVEN BOX FROM GRILL UNTIL IT IS COMPLETELY COOL.** Allow at least 90 minutes after turning off grill to remove. If using a charcoal grill additional cooling time may be required. Do not use water or other solvents to aid in cooling the Pizza Oven Box after use.
- ⚠ Do not place gasoline, alcohol, wood products, charcoal or any other combustible material (unless BakerStone approved) in the baking chamber.
- ⚠ The Pizza Oven Box must never be used indoors or for heating purposes.

Table of Contents	Page
What's in the package	3
Assembly of the Pizza Oven Box	4
Assembly of the Pizza Turner	7
What's Needed to Bake Pizza	8
How To Use the Pizza Oven Box	9
Care Instructions	12
Customer Service	12
Basic Dough Recipe	13
Pizza Sauce Recipe	14
Margherita Pizza Recipe	15
Roasted Pork Loin Chops Recipe	16
Frequently Asked Questions	17

Product Guide

Before assembling your Pizza Oven Box, ensure that all parts below are included.
NOTE: The Back Panel (B) and Stone Supports (C) are pre-assembled and must be removed prior to installing the Stones (D-G). You will be re-attaching these parts during the assembly process.

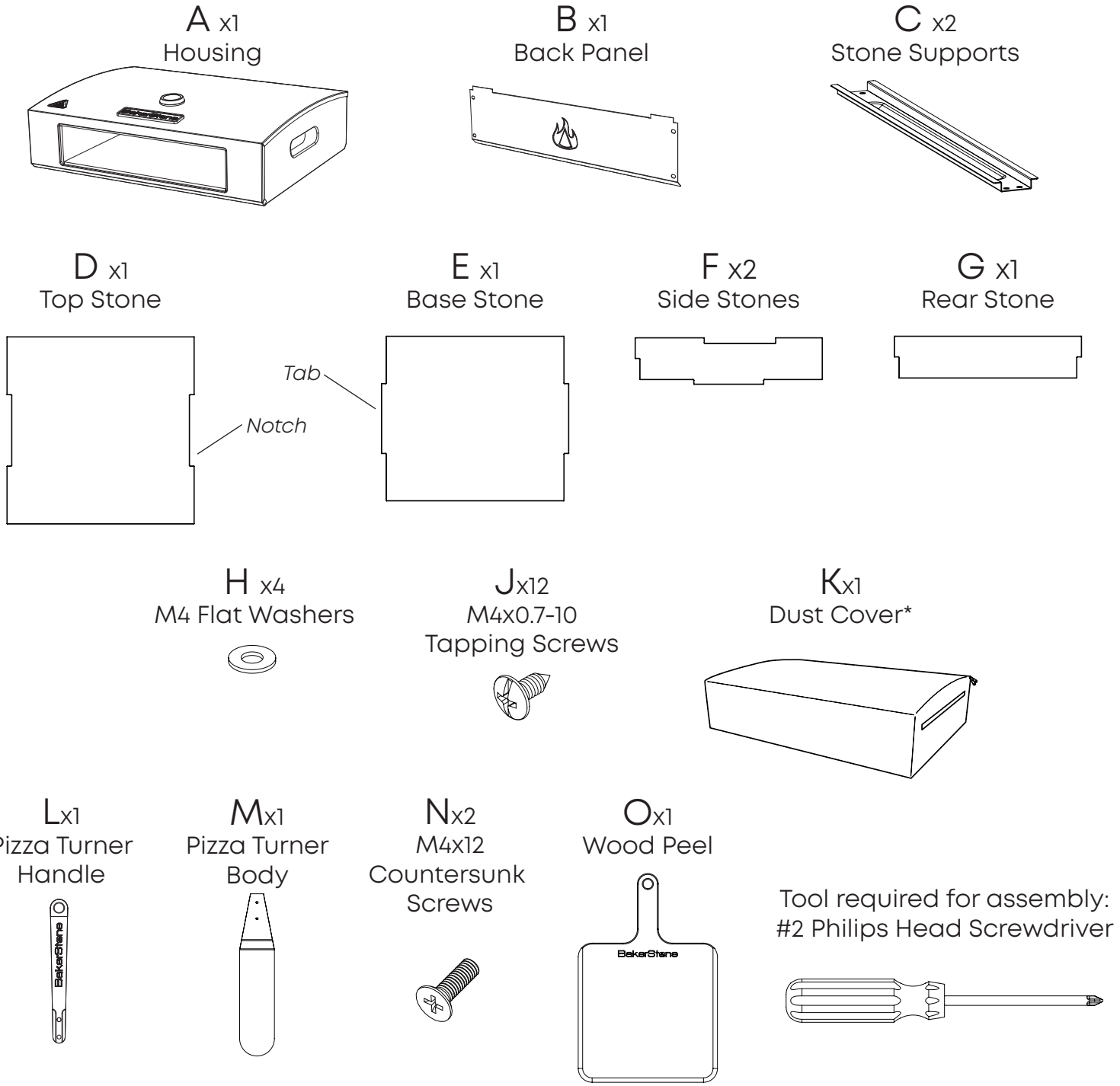

Have a question?
Please Do Not Return This Product To The Store. Contact us first!
1-855-657-6836 or email support@bakerstonebox.com

* NOTE: Dust Cover is intended to protect the Pizza Oven Box from accumulating dust while in storage. Do not store the Pizza Oven Box or Dust Cover outdoors. Dust Cover is not water resistant.

Assembly of the Pizza Oven Box

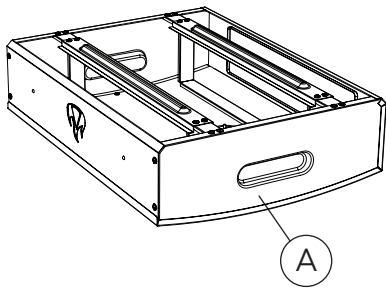

STEP 1 Place the HOUSING (A) carefully upside down on a clean, soft surface. **NOTE:** Failure to do so may result in scratching or denting the Pizza Oven Box.

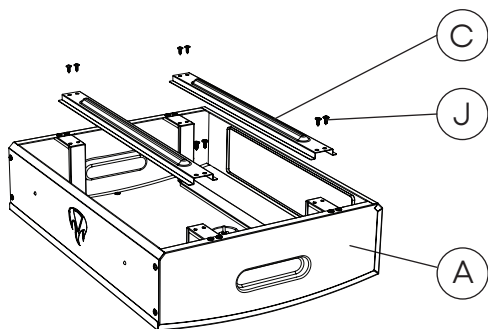

STEP 2 Remove the STONE SUPPORTS (C) from the HOUSING (A) by removing 8 SCREWS (J).

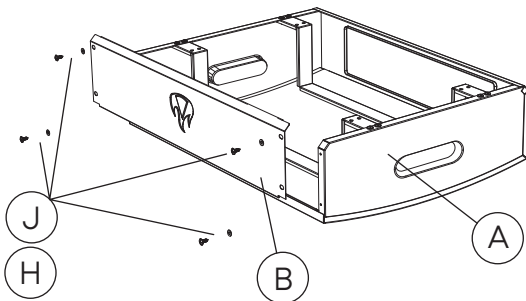

STEP 3 Remove the BACK PANEL (B) from the HOUSING (A) by removing its 4 SCREWS (J) and 4 FLAT WASHERS (H). You will identify the BACK PANEL (B) by the embossed BakerStone flame logo on this panel.

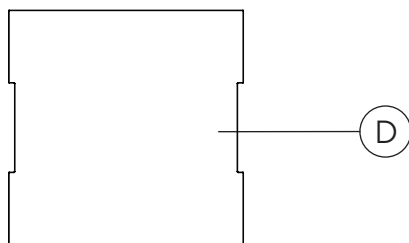

STEP 4 Identify the TOP STONE (D), this is the largest stone in the box. **NOTE:** There are notches on both sides of this stone.

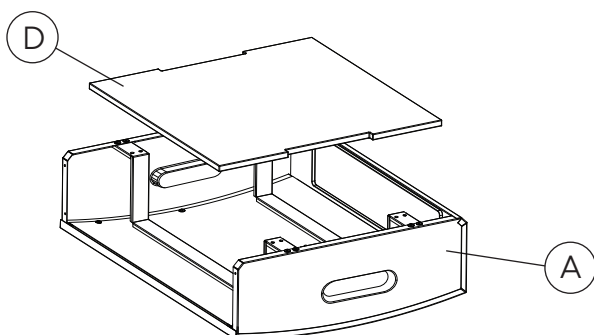

STEP 5 Gently fit the TOP STONE (D) into the Stone Cradles of the HOUSING (A).

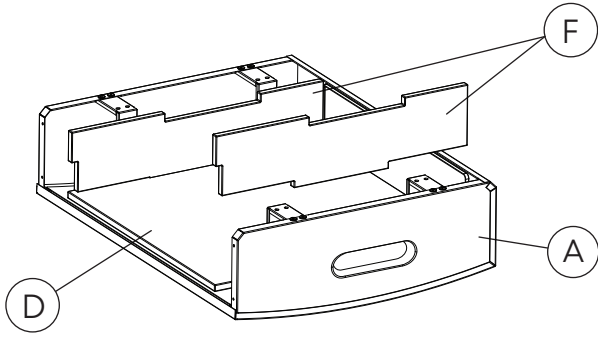

STEP 6 Identify the 2 SIDE STONES (F). Fit the 2 SIDE STONES into the notches of the TOP STONE (D). **NOTE:** The flat end of the SIDE STONES (F) should face the front of the oven.

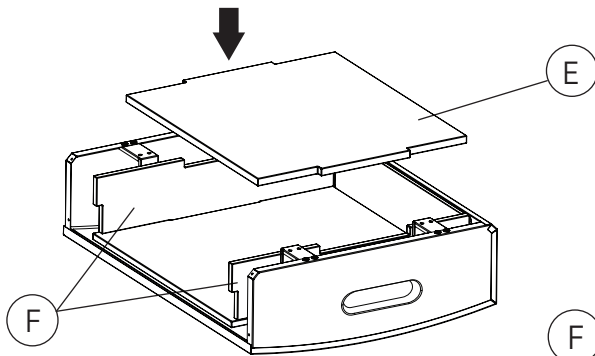

STEP 7 The other large stone is the BASE STONE (E). Fit this in between and on top of the 2 SIDE STONES (F).

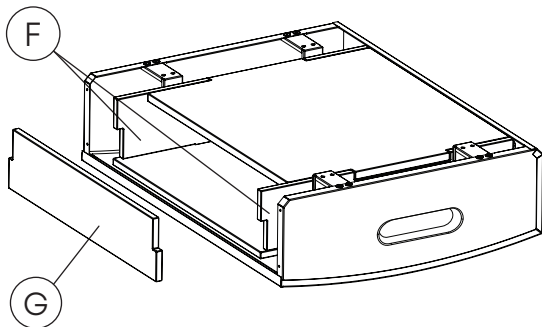
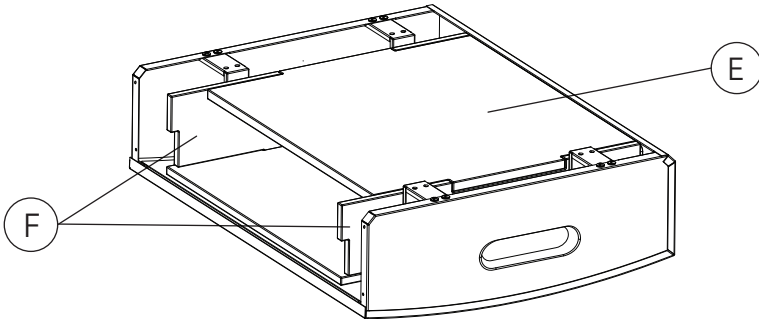

STEP 8 Fit the remaining REAR STONE (G) into the notches of the 2 SIDE STONES (F).

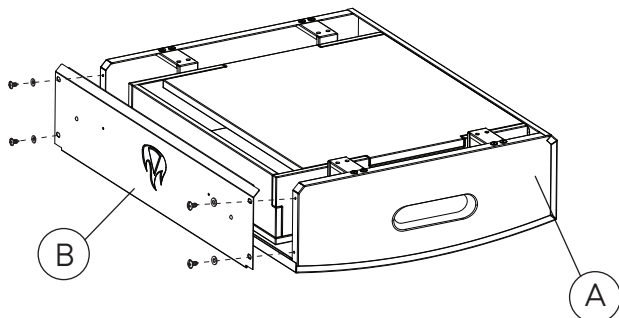

STEP 9 Place the BACK PANEL (B) back onto the HOUSING (A) and secure with 4 SELF TAPPING SCREWS (J) and 4 FLAT WASHERS (H). **NOTICE: Do not over tighten screws, cracking of the enamel finish may occur.**

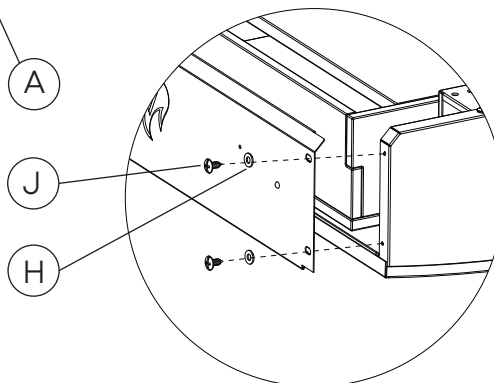

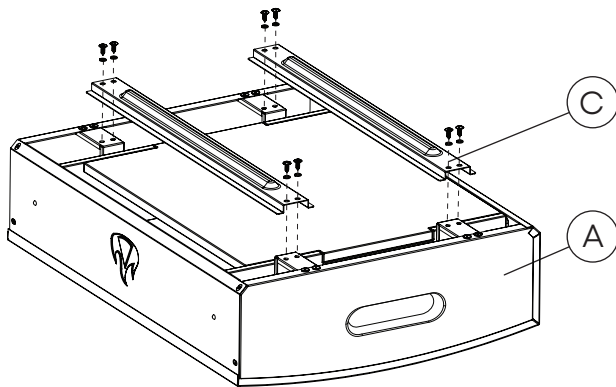

STEP 10 Place the STONE SUPPORTS (C) across the HOUSING (A) and secure with SELF TAPPING SCREWS (J). **NOTE:** The flat side of the STONE SUPPORTS (C) faces toward the stones and the protruding ridge faces up. **NOTICE: Do not over tighten screws, breakage of stones may occur.**

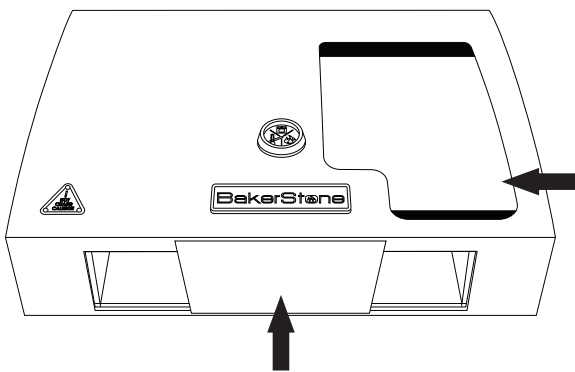
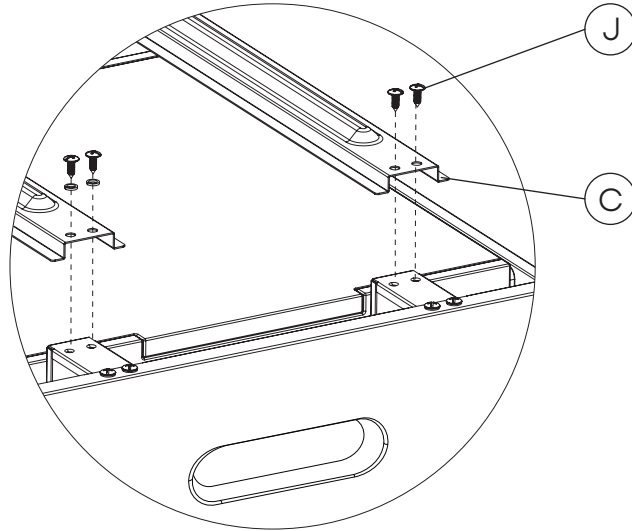

STEP 11 Turn the Pizza Oven Box over and place on grill when ready to bake. **NOTICE: Remove all stickers before placing on grill.**

NOTE: Before using your Pizza Oven Box for the first time, wipe the base stone with a damp cloth to remove any packaging debris.

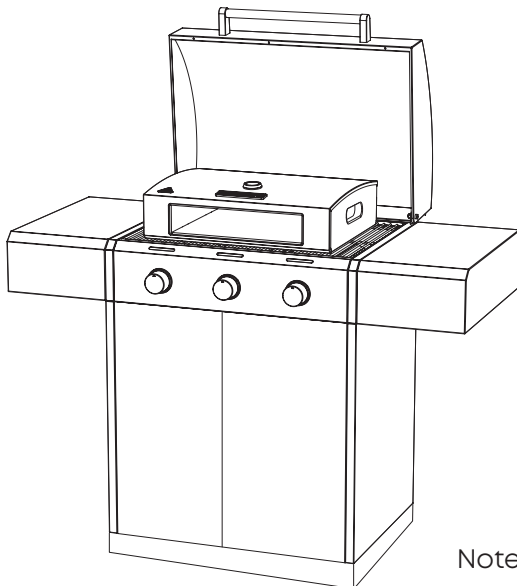

NOTE: If your Pizza Oven Box does not reach the proper baking temperature, your grill may utilize extra heat tents or Flavorizer® bars. These components sit between the cooking grate and the burners and deflect the heat from the burners downward. Once your grill has completely cooled, remove these pieces and try again. If you have an infrared grill, you will need to remove the heat shield that sits between the cooking grate and burners as this shield will block the heat from reaching the Pizza Oven Box.

Note: Grill not included.

Pizza Turner Assembly

STEP 1 The Pizza Turner requires assembly prior to use. Locate the TURNER HANDLE(L) and TURNER BODY(M) in the Accessory Kit box.

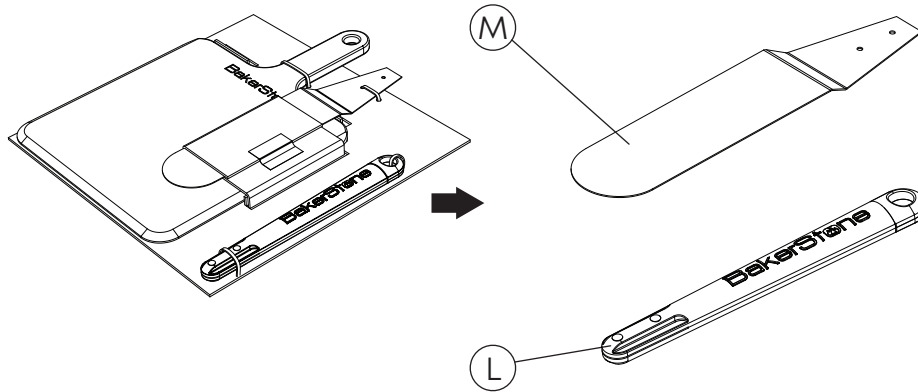

STEP 2 Insert the TURNER BODY(M) into the TURNER HANDLE(L). Ensure the holes in the TURNER BODY(M) line up with the holes in the TURNER HANDLE(L).

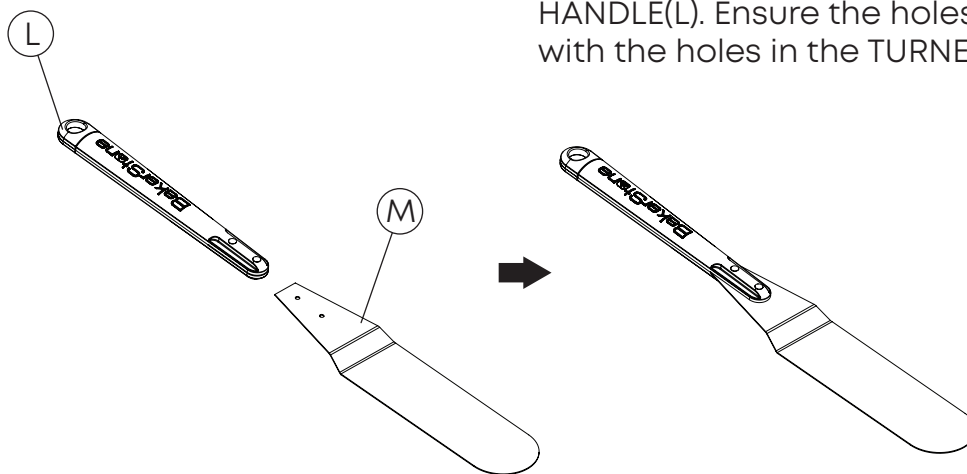

STEP 3 Install the two COUNTERSUNK SCREWS(N) into the bottom side of the TURNER HANDLE(L), tighten until snug.

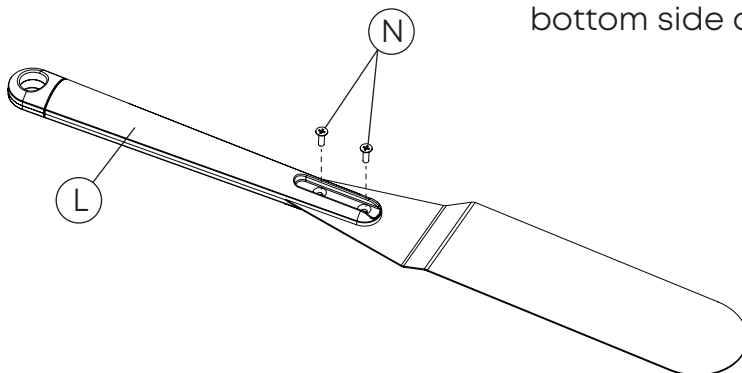

This is what is needed to create a gourmet pizza.

Ingredients	Notes
Pizza Dough*	Store bought or home made.
Pizza Sauce	Store bought or home made.
Cheese	Fresh mozzarella is excellent or you can use your favorite cheese.
Herbs, Spices and Salt	Use Fresh Basil or Oregano and a nice Sea Salt.
Olive Oil	Use a good quality Extra Virgin Olive Oil for best flavor.
Toppings	Use chopped/sliced vegetables, pre-cooked meats, etc. Get creative!

*Ready to use pizza dough is available in many supermarkets, grocery stores, pizzerias, and gourmet food shops near you. *Ask for it;* using fresh pizza dough will greatly enhance your BakerStone pizza experience. With a little practice, you'll be creating your own gourmet pizza in no time at all!

Equipment	Notes
3-burner or larger gas grill	
BakerStone Pizza Oven Box	
Wooden Pizza Peel	This is an inexpensive tool that will make all the difference in your quest for creating your own gourmet pizza. A Wooden Pizza Peel dusted with flour will enable you to prepare and top your pizza and then easily launch them into the Pizza Oven Box with success and confidence time and time again.
Pizza Turner	Another inexpensive yet indispensable tool, the Long-Handled Spatula or Pizza Turner will enable you to effortlessly rotate and tend to your gourmet pizza or other bread items while they bake in the Pizza Oven Box.
Metal Pizza Peel	The final quintessential tool in your quest for creating your own gourmet pizza is the Metal Pizza Peel. This thin bladed tool allows you to expertly remove and transport your gourmet pizza to your adoring fans.



How to use your Pizza Oven Box

⚠ WARNING: Please completely read all safety precautions at the beginning of and throughout this guide before using your Pizza Oven Box. The Pizza Oven Box becomes extremely hot and can cause burns. Failure to follow precautions when using the Pizza Oven Box can result in serious injury and/or property damage.



STEP 1 Open the lid on the gas grill that will be used with the Pizza Oven Box. **WARNING: Gas grill lid must remain OPEN AT ALL TIMES** while the Pizza Oven Box is on the grill. **NOTICE: If your BBQ/Grill configuration includes a HOT PLATE (Griddle), remove this prior to use and center the remaining section of open grill plate in the BBQ/Grill and place the BakerStone Pizza Oven Box on top.**



STEP 2 Place the Pizza Oven Box on the cooking grate of the grill, leaving a 0.5”(1.2cm) space between the front edge of the Pizza Oven Box and the front edge of the cooking grate of the grill and at least 1”(2.5cm) of space between both side edges of the Pizza Oven Box and both side edges of the cooking grate.



0.5” (1.2cm)

1.0” (2.5cm) or more

WARNING: Failure to leave the spaces indicated above may result in restricted airflow and improper ventilation for your grill. This could result in serious injury and/or property damage. **DO NOT USE THE PIZZA OVEN BOX WITH YOUR GAS GRILL IF YOU CANNOT LEAVE ADEQUATE SPACE FOR VENTILATION AS DESCRIBED ABOVE.**

STEP 3 With the gas grill lid completely open and proper spaces surrounding the Pizza Oven Box, light your gas grill as instructed by the gas grill manufacturer.

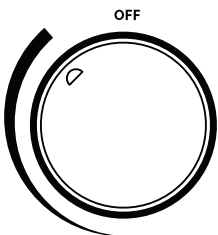

STEP 4 Set all burners to HIGH and preheat the Pizza Oven Box for 20 minutes.

Note: Grill not included.





Temperature Range Indicator

STEP 5 Adjust the burner settings on the gas grill to obtain the desired temperature range for the foods that are being baked. **NOTE: It will take 15 minutes for the temperature range indicator to function.**

For baking items such as Breads and Cookies, adjust the heat of the grill so that the indicator reads in the  baking zone.

For Pizza and Roasting Meats and Vegetables, adjust the heat so that the indicator reads in the  baking zone.

 = 200°-500°F
93°-260°C

 = 500°-800°F
260°-427°C

NOTE: Temperature range indicator is not an accurate measuring instrument.

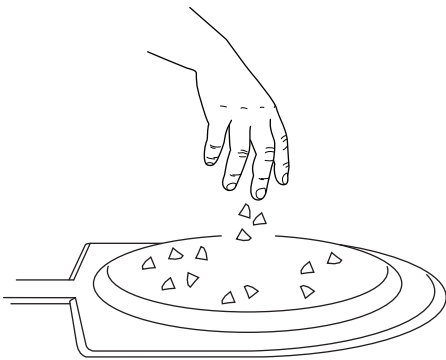

STEP 6 Dust a Wooden Pizza Peel with flour (approximately 2 Tbsp of flour) and spread around board to evenly coat the entire peel. Then, holding the peel at a 45 degree angle over a sink, gently tap the peel to remove the excess flour. **NOTE:** This will ensure that the pizza does not stick to the peel when launching the pizza into the Pizza Oven Box.

STEP 7 Place a hand-stretched or rolled-out pizza dough on the floured Pizza Peel. Create your pizza using your favorite sauce and toppings.

STEP 8 Using the pizza peel, launch your pizza into the Pizza Oven Box.

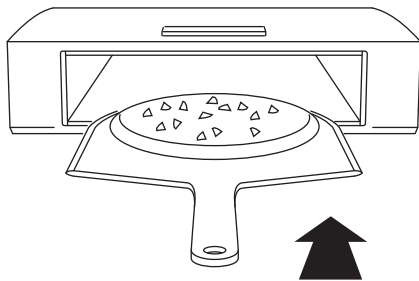

NOTE: This can be accomplished by placing the pizza peel just over half-way into the Pizza Oven Box, and using a quick back and forth shaking motion while sliding the peel out of the Pizza Oven Box. See www.bakerstonebox.com website for a video demonstration.

WARNING: Failure to use pizza peel to insert pizza can result in serious injury.

NOTE: Do not allow food other than Pizza or Bread Dough to contact the stones. Any foods that contain fat, oil or butter (meats, items coated with olive oil, cookies, biscuits, etc.) should not contact the stones directly. These items should be baked in a metal baking pan, on a metal baking sheet or in a cast-iron skillet as the stones will absorb the fat, oil and butter which can cause smoking, odors, staining, and can impart rancid flavors to items that you bake in the future.

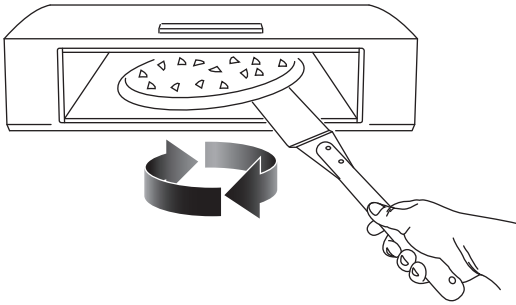

STEP 9 Bake the pizza for 1 minute* to allow the crust to set.

STEP 10 After 1 minute*, use a long spatula or Pizza Turner to rotate the pizza 1/4 to 1/3 turns roughly every 45 seconds*. Bake your pizza for approximately 2-4 minutes*, being careful not to burn your pizza.

NOTE: The Pizza Oven Box is hottest in the back. Periodically rotate your pizza to ensure it is baked evenly.

WARNING: Touching the Pizza Oven Box anywhere with your bare hand or skin could cause serious injury.

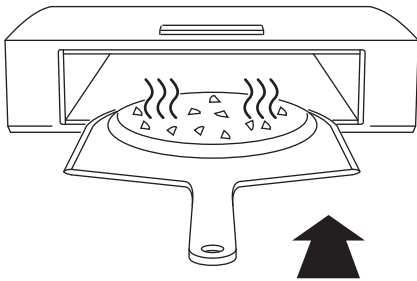

STEP 11 Using a Metal Pizza Peel, remove the fully cooked pizza from the Pizza Oven Box and transfer to a cutting board or serving tray and allow to cool.

NOTE: The pizza will be very hot when you remove it from the Pizza Oven Box. **WARNING: Removing the pizza with anything but the pizza peel could result in serious injury.**

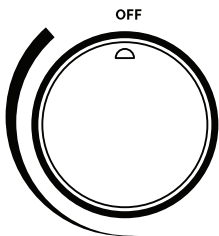

STEP 12 When finished baking, turn the burners on the gas grill to the off position and allow the gas grill and the Pizza Oven Box to cool for a period of at least ninety (90) minutes. **NOTE:** If cleaning is required, leave the burners on and continue to heat the oven for 15 minutes prior to cleaning. After cleaning, turn the burners on the gas grill to the off position and allow the gas grill and the Pizza Oven Box to cool for a period of at least ninety (90) minutes [See Care and Cleaning instructions].

WARNING: Serious injury can occur if the gas grill and Pizza Oven Box are not allowed to completely cool and you touch them.

***Cooking times are provided as basic guidelines. Times can vary depending on weather conditions, gas grill condition and gas grill performance.**

Care & Cleaning

Let the Pizza Oven Box cool completely before removing from gas grill.

Do not use household cleaners or liquids on stones.

Do not use household cleaners on metal housing.

Wipe outer housing with a soft damp cloth only when completely cooled.

After baking your final pizza, you can clean the Pizza Oven Box by letting the burners remain on high for approx 15 minutes. Any residue should burn off and debris can be pushed to the back of the oven.

Darkening of the stone from ingredients or excess flour will occur over time and will not affect baking performance of the Pizza Oven Box.

NOTE: *Do not allow food other than Pizza or Bread Dough to contact the stones. Any foods that contain fat, oil or butter (meats, items coated with olive oil, cookies, biscuits, etc.) should not contact the stones directly. These items should be baked in a metal baking pan, on a metal baking sheet or in a cast-iron skillet as the stones will absorb the fat, oil and butter which can cause smoking, odors, staining, and can impart rancid flavors to items that you bake in the future.*

Customer Service

For general inquiries, please email us at support@bakerstonebox.com or call **(855) 657-6836**.

For **North American** customer service needs, such as replacement parts and warranty claims, please email us at support@bakerstonebox.com or call **(855) 657-6836**.

For customer service needs in Australia please contact:
Freephone: 1800 839 842 / www.bakerstonebox.com.au
customercare@bakerstonebox.com.au

For customer service needs in **New Zealand** please contact the New Zealand distributor: **Riverlea Group Ltd.** / Freephone: 0800 438 274
email: customercare@riverleagroup.co.nz
website: www.riverleagroup.co.nz

BASIC PIZZA DOUGH - makes: 6 to 8 Dough Balls

INGREDIENTS

8 Cups (1000g) - Flour (50/50 mixture of All purpose and Bread Flour)
21 oz. (600mL) - Water (cool not cold tap water)
1/2 tsp. (2.8g) - Fresh Yeast
 or 2 tsp. (2.2g) - Active Dry Yeast**
 or 2 tsp. (2.2g) - Instant Dry Yeast**
2 Tbsp. (28g) - Finely ground Sea Salt

EQUIPMENT

Stand Mixer
Measuring cup
Measuring spoons

DIRECTIONS (Stand Mixer Method)

- STEP 1** Pour the WATER in the mixing bowl and add the YEAST. If using FRESH YEAST, work the YEAST with WATER in your palm until it dissolves. For ADY** or IDY**, mix into water and stir to dissolve. Let rest for 5 minutes.
- STEP 2** Attach dough hook and turn on to the lowest setting; slowly incorporate 70-80% of the flour into the WATER & YEAST mixture - approximately 3 minutes. Once combined, remove bowl from the mixing stand, cover with a damp towel or plastic wrap and let stand for 30 minutes. Then, return bowl to mixing stand on the lowest setting and slowly incorporate the remaining FLOUR & SEA SALT into the dough - approximately 2 to 3 minutes.
- STEP 3** Continue mixing on the lowest setting for 10 minutes, if dough forms a ball around the dough hook, stop mixer and remove dough from the hook, then resume mixing. If the dough feels too warm, stop mixer for 30 seconds to 1 minute and resume mixing.
- STEP 4** Place the dough on a clean counter and form a 2 to 3 inch (5cm to 7.6cm) thick rectangular mass, cover it with a damp towel or plastic wrap. Let the dough rest for 1½ to 2 hours.
- STEP 5** To create the dough balls cut the mass of dough into 2 strips. Hold the end of one dough strip in one hand, and using the thumb and fore-finger of your other hand, slowly tighten them around the base of the dough ball where you want to cut through the dough. Do not rip or tear the dough. You should get 3 to 4 dough balls out of each strip.
- STEP 6** Place the dough balls into a lightly dusted container(s) and cover with lid or plastic wrap.
- STEP 7 Choose from one of these two FERMENTATION METHODS:**
- 1.) Warm Ferment:** let your dough rest on the counter in a cool dry place (around 70°F/21°C) for 4 to 6 hours, and then you're ready to make pizza!
 - 2.) Cold Ferment:** let it rest in the refrigerator for anywhere from 12 hours up to 3 days. The longer that you let the dough rest, the more complex the flavor development becomes.
- *NOTE: If you use the cold ferment method, make sure to take your dough out of the refrigerator 2 to 3 hours prior to baking pizzas so the dough will stretch more easily.*

Experiment with the different methods to determine your favorite type of crust.

PIZZA SAUCE - makes: 28 oz.(793g) Pizza Sauce

INGREDIENTS

One 28 oz. (793g) - Can of Whole Peeled Tomatoes

San Marzano Tomatoes are the preferred style of tomatoes but you can use your favorite brand of whole peeled tomatoes or whole peeled tomatoes with basil. Look for a brand that says "in puree" for best results.

1 tsp. (5.7g) - Sea Salt

A finely ground sea salt will incorporate into the sauce more evenly than a coarsely ground sea salt. Add more to taste 1/2 tsp.(2.8g) at a time.

EQUIPMENT

Food Processor

Blender

Food Mill

DIRECTIONS

STEP 1 Open can of tomatoes and drain them, preserving the puree or liquid.

STEP 2 Place tomatoes into your Food Processor, Blender or Food Mill.

STEP 3 Add the SEA SALT to the TOMATOES.

STEP 4 FOOD MILL - Manually run your Food Mill using the Coarse Plate until only the skins remain in the bowl of the Food Mill.

FOOD PROCESSOR - Using the PULSE setting on your Food Processor, chop until you achieve a thick sauce-like consistency.

BLENDER - Using the PULSE setting on your Blender, blend until you achieve a thick sauce-like consistency (you may need to add a small amount of the reserved puree/liquid to get the contents of the Blender moving).

STEP 5 Transfer the blended sauce to a bowl and add the reserved puree/liquid to the sauce and stir to combine.

A Food Mill with the coarse plate provides the best results as you do not have to worry about over blending and making your sauce too thin. A Food Processor and Blender work well, just make sure you use the PULSE setting so you can control the consistency by using short bursts of blending until you achieve your desired consistency.

MARGHERITA PIZZA - *makes: One 12"(30cm) Pizza*

INGREDIENTS

One - Pizza Dough Ball
2 oz. (59g) - Pizza Sauce
3 oz. (85g) - Fresh Mozzarella, torn
6-10 - Fresh Basil Leaves, torn
1/2 - 1 cup (62.5-125g) - Flour for dusting the peel and coating the Pizza Dough
Sea Salt (fine or coarse are acceptable)
Extra Virgin Olive Oil

EQUIPMENT

Pizza Peel (Wooden)
Ladle or Large Spoon
Round Pizza Turner or Spatula
Metal Pizza Peel (Optional)
Rolling Pin (Optional)

DIRECTIONS

- STEP 1** Preheat the Pizza Oven Box for 15 to 20 minutes.
- STEP 2** Before you begin dust the Pizza Peel (Wooden) with flour.
- STEP 3** Coat pizza dough with flour on both sides and brush off the excess.
- STEP 4** Hand-stretch or use a Rolling Pin to roll the pizza dough into a 12 inch disk.
- STEP 5** Place your stretched pizza dough onto the Pizza Peel (Wooden) and then rub a small amount of Extra Virgin Olive oil over the edge of the crust for even browning.
- STEP 6** With a ladle or large spoon, add the pizza sauce and spread evenly around the pizza.
- STEP 7** Add the Mozzarella cheese generously and evenly over the pizza sauce.
- STEP 8** Sprinkle the Sea Salt over your pizza.
- STEP 9** Lightly drizzle Extra Virgin Olive Oil over your pizza, beginning in the center and using a circular/spiral motion moving towards the outer edge.
- STEP 10** Launch your pizza into your Pizza Oven Box and cook for 1 minute, then Rotate 1/4 to 1/3 turn.
- STEP 11** Rotate your pizza using a 1/4 to 1/3 turn every 30 to 45 seconds to evenly brown your pizza.
- STEP 12** Remove the pizza with the Metal Pizza Peel (approx 2 1/2 to 3 min*) and add the fresh Basil leaves over the pizza. Return it to the oven and cook for another 30 to 45 seconds.
- STEP 13** Remove and enjoy!

*Performance may vary.

ROASTED PORK LOIN CHOPS with HARICOTS VERTS & GRAPE TOMATOES

serves: 2 to 3

INGREDIENTS

2 Center Cut Pork Chops 1.5”(4cm) thick
15 to 20 Grape (or Cherry) Tomatoes
1/2 Lb. (225g) - Haricots Verts (or Green Beans)
1 Tbsp. (15mL) - Extra Virgin Olive Oil
Lemon Pepper
Garlic Powder
Salt
Pepper

EQUIPMENT

2 Oval Cast Iron Steak/Fajita Plates
or 1 Cast Iron Skillet 10” to 14” (26cm to 36cm) diameter
High Temperature Oven Mitts
Metal or Heat-Resistant Tongs
Meat Thermometer

DIRECTIONS:

STEP 1 Preheat the Pizza Oven Box on High for 15 to 20 minutes.

STEP 2 Season the Pork Chops with Lemon Pepper, Garlic Powder, Salt, and Pepper.

STEP 3 Lightly coat the Haricots Verts & Grape Tomatoes with Olive Oil and add Salt & Pepper to taste.

STEP 4 Place the Pork Chops onto the Cast Iron Plates or Skillet and arrange the Haricots Verts & Grape Tomatoes around the Pork Chops.

STEP 5 Using the High Temperature Oven Mitts, carefully place the Cast Iron Plates or Skillet into the Pizza Oven Box and roast for 4 to 5 minutes.

STEP 6 Using the High Temperature Oven Mitts, carefully rotate the Cast Iron Plates or Skillet 180 degrees (if the Skillet handle prohibits this, then use the Tongs to rotate the Pork Chops instead) and continue roasting another 4 to 5 minutes, or until the Meat Thermometer reads (145°F/62.8°C) when inserted into the middle/center of the thickest section of the Pork Chops.

STEP 7 Using the High Temperature Oven Mitts, carefully remove the Cast Iron Plates or Skillet from the Pizza Oven Box and place upon a heat-resistant surface.

STEP 8 Using the Tongs, carefully remove the Pork Chops from the Cast-Iron Plates or Skillet and place them upon a cutting board, serving platter or plate and allow to rest for 3 to 5 minutes.

STEP 9 After the resting period, serve with Haricots Verts & Grape Tomatoes and enjoy!

*Performance may vary.

Frequently Asked Questions

Why is my Pizza Oven Box not getting hot enough?

If your Pizza Oven Box does not reach the proper baking temperature, your grill may utilize extra heat tents or Flavorizer® bars. These components sit between the cooking grate and the burners and deflect the heat from the burners downward. Once your grill has completely cooled, remove these pieces and try again. If you have an infrared grill, you will need to remove the heat shield that sits between the cooking grate and burners as this shield will block the heat from reaching the Pizza Oven Box.

Can I close the lid of my grill while using the Pizza Oven Box?

We advise you to keep the lid of your grill in the fully opened position while using the Pizza Oven Box in order to protect you and your grill. If you fully or partially close your grill lid while using the Pizza Oven Box, it may cause components of your grill to overheat which may result in damage to your grill and/or bodily injury should you touch the overheated components.

How do I clean the Pizza Oven Box?

To clean the stones, let the burners remain on high for approximately 15 minutes. The remaining residue should burn off or can be scraped off and pushed to the back of the oven by using a long handled Cleaning Brush. Do not use any cleaning agents or other liquids to clean the stones. Once the oven has cooled completely, a damp cloth can be used to wipe off any char left in the oven. The stone will remain blackened and/or darkened which is natural. If this does not clean the stone to your satisfaction, you can also remove the Support Brackets and flip the Base Stone over (horizontally) and replace the Support Brackets. This will give you a clean Base Stone to use and the next time you use the Pizza Oven Box, any remaining residue will burn off.

Why don't the notches line up with the Stone Supports or Stone Cradles?

The notches and Stone Supports or Stone Cradles are not supposed to line-up.

I have knocked and/or dropped my oven while moving it and cracked a stone, will it still work?

Yes, small cracks have no effect on cooking performance. Wipe the area with a damp cloth to remove any loose stone particles before using.

Where can I purchase replacement parts?

Depending on your location, you can purchase replacement parts from the following links:

U.S.A.: <http://shop-usa.bakerstonebox.com/>

Canada: <http://shop-canada.bakerstonebox.com/>

Australia: <http://www.bakerstonebox.com.au/>

Europe: <http://www.lahacienda.co.uk/products/bakerstone-pizza-oven-box>

New Zealand: <http://www.bakerstonebox.co.nz/>